

Installation

MF2949/IR

Terreon® Quadra-Fount™ Wall-Hung Washfountain with Adaptive Infrared Control

(Standard*, Juvenile* and OBC Height)

* Standard and Juvenile Height are ADA/TAS Compliant



Table of Contents

Pre-Installation Information	2
Parts Included with the Quadra-Fount™	3
Installation Instructions	4-8
Cleaning and Maintenance	9-10
Troubleshooting	11-12

IMPORTANT!

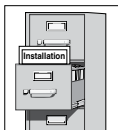

Read this entire installation manual to ensure proper installation. When finished with the installation, file this manual with the owner or maintenance department.



Separate parts from packaging and make sure all parts are accounted for before discarding any packaging material. If any parts are missing, do not begin installation until you obtain the missing parts.

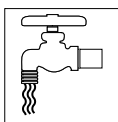

Water supply requires a flowing pressure of at least 20 psi, but no greater than 80 psi.

Make sure that all water supply lines have been flushed and then completely turned off before beginning installation. Debris in supply lines can cause valves to malfunction.

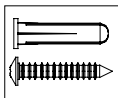

Hardware supplied by installer must be appropriate for wall construction. Wall anchors used must have a minimum pull-out rating of 1,000 lbs.



The adaptive infrared control must be connected with a 24 VAC Class II transformer. Connections to 110 VAC can cause personal injury and will result in damage to the electronics.



Product warranties may be found under “Product Information” on our web site at www.bradleycorp.com.

Supplies Required by Installer

- (6) 3/8" diameter bolts with washers and (6) wall anchors appropriate for your installation
- 1/2" nominal copper tubing for hot and cold water supply lines
- 1-1/2" NPT drain trap and waste connection
- Pipe sealant and plumber's putty
- 110 VAC power source for 110/24 VAC plug-in transformer supplied
- OPTIONAL: Bradley recommends installing an electrical cut-off switch to the unit. This feature prevents accidental water delivery during regular maintenance and service.

Pre-Installation Information

Terreon material

The Quadra-Fount is constructed of Terreon, a densified solid surface material composed of polyester resin. Terreon is resistant to chemicals, stains, burns and impact. Surface damage can be easily repaired with everyday cleaners or fine-grit abrasives. Terreon is NAHB certified to meet ANSI Z124.3, Z124.6 and ANSI/ICPA SS-1-2001.

Adaptive sensor and solenoid valve

Each nozzle is controlled by a separate solenoid valve, allowing each user to activate a flow of tempered water from one spray nozzle. Each valve uses less than half the maximum amount of hot water allowed by the ANSI/ASHRAE/IES 90A-1980 Standard.

Adaptive Infrared sensor: The Adaptive sensor modules are housed in the sprayhead. The sensor eyes are secured behind the sprayhead to protect it from water, soap and dirt. The sensor is accessible by removing the top cover. All electrical components are housed within the pedestal.

Solenoid valve: An electronically controlled solenoid valve serves as the metering mechanism. Few moving parts provide reliable metering performance and the solenoid is unaffected by chemicals and minerals often present in municipal water supplies.

Barrier-free and ADA compliant

The Terreon Quadra-Fount with Adaptive Infrared is designed to comply with all ADA and TAS guidelines on reaches, clearances and operation ***when mounted at standard or juvenile height dimensions by the installer.***

Parts included with the Wall-Hung Quadra-Fount

Separate all parts from packaging materials and ensure you have all the parts required for assembly. If any parts are missing, do not attempt to assemble the Quadra-Fount™ until you obtain all parts.

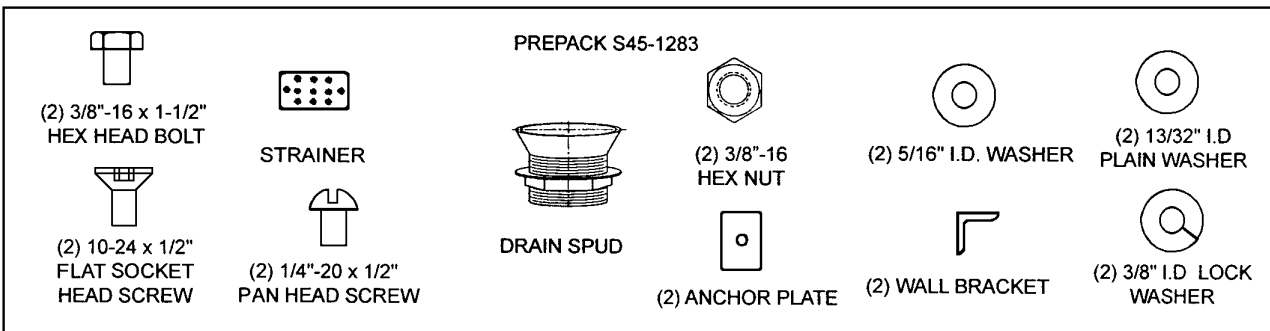
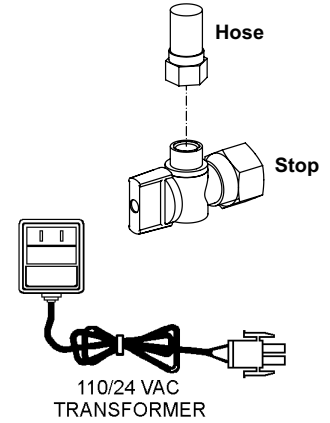
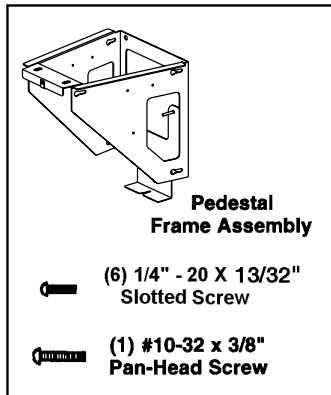
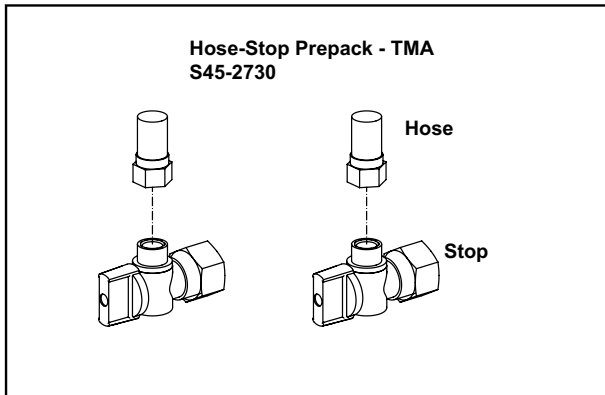
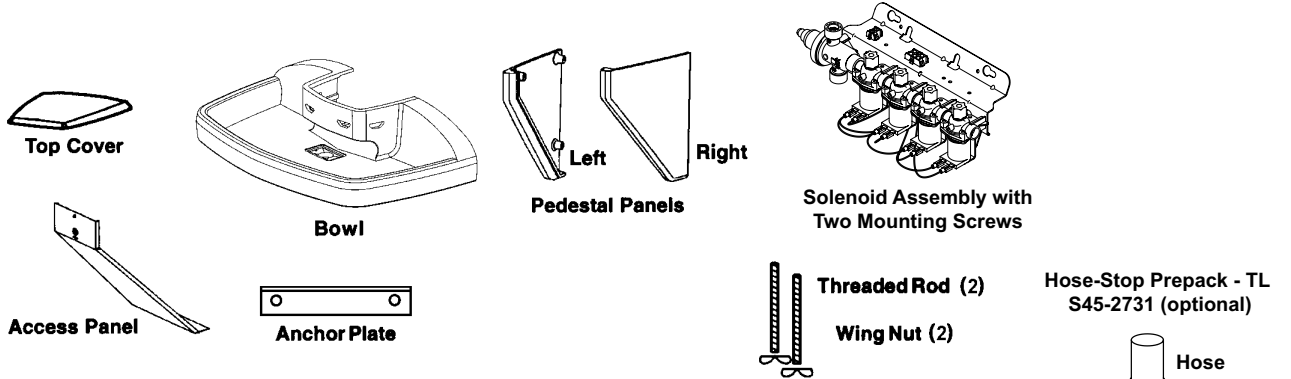

1 Rough-Ins

A Rough in 1/2" nominal copper tubing for hot and cold supply lines through wall at dimensions shown.

B Rough in 1-1/2" NPT drain waste connection through wall at dimensions shown.

C Drill four 1/2" diameter holes in the wall using the pedestal frame as a template.

D Secure the pedestal frame to the wall anchors using four 3/8" diameter bolts and washers (supplied by installer).

! Flush the supply lines before making connections. Debris in supply lines will cause the valves to malfunction.

! The Quadra-Fount must be connected with a 24 VAC Class II plug-in transformer. Connection with 110 VAC will result in damage to the electronics and could result in personal injury.

! Make sure the frame is level when using as a template for drilling anchor holes.

✓ Compliance and conformity to local codes and ordinances is the responsibility of the installer.

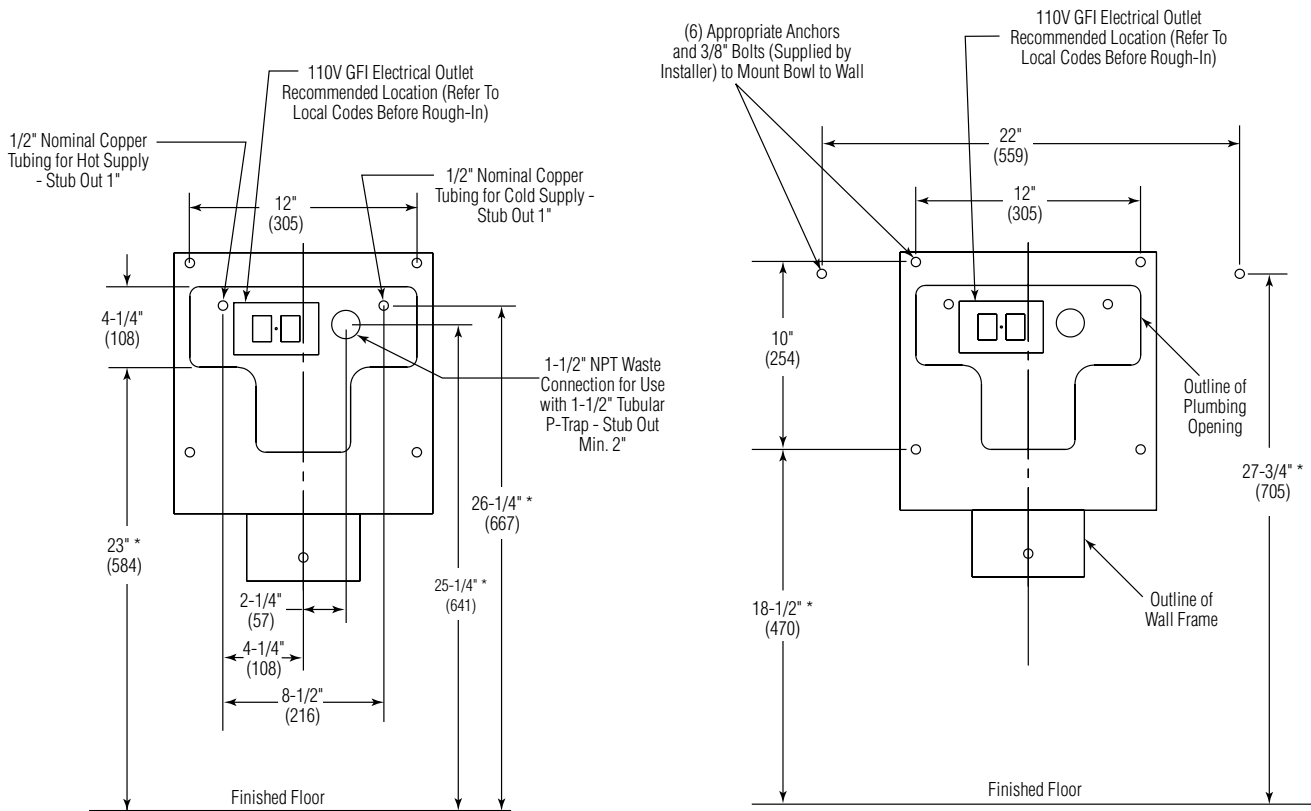

* Subtract 1" from these dimensions for Ontario Building Code height or 4" for Juvenile Height Model.

2 Install Solenoid Assembly

 The letter "H" on the Navigator® mixing valve indicates hot water supply inlet.

A Attach the stops to hot and cold water rough-ins.

B Connect one end of each supply hose to the stops.

C Inside the pedestal, install the two 1/4" - 20 x 1/2" screws (supplied with solenoid assembly) in the mounting holes on the side of the left side of the frame. Do not thread the screw completely into the frame, but allow 5/16" of the screw to be exposed.

D Connect the other end of each supply hose to the Navigator® TMV valve assembly (one on the hot side, one of the cold side).

E Hang the solenoid assembly on the exposed portion of the screws.

F For optional single tempered supply: attach the stop to the 1/2" tempered supply line. Connect the stop to the solenoid valve assembly with the flexible supply hose.

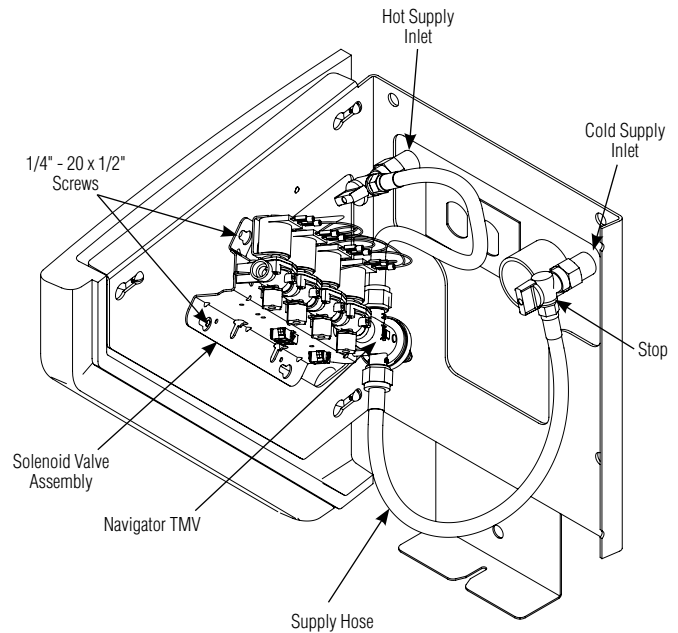

3 Install Pedestal Panels

 Remove molding strips or tiles which could prevent a flush mounting to the wall.

A Install three 1/4 - 20 x 13/32" screws (provided) on each pedestal panel so that about 3/16" of each screw is exposed. Do not tighten screws.

B Slide each of the pedestal onto the frame assembly such that the exposed portions of the screws fit into the slots on the frame assembly. Slide the pedestal panel toward the wall until the screws fit in the narrow end of the notches in the frame assembly.

C Tighten the screws to secure the pedestal panels to the frame assembly.

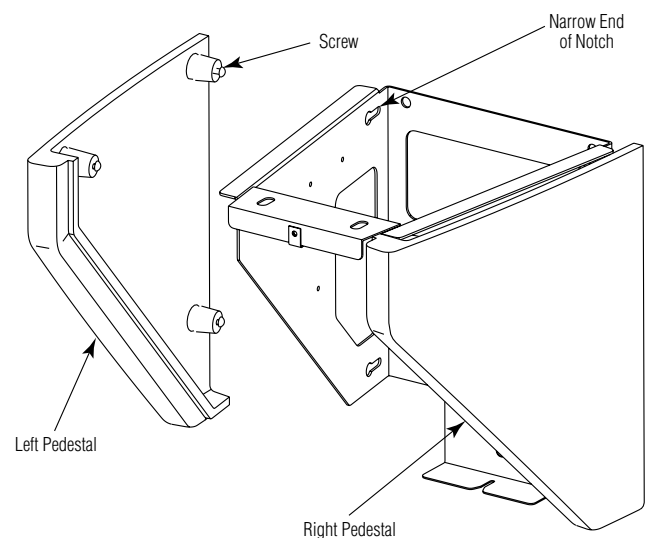

4 Assemble and Install Bowl



Do not leave the bowl on the pedestal unsupported, as it may fall and cause personal injury or damage to property.



Discard rubber gasket included with drain spud. It cannot be used in this application.

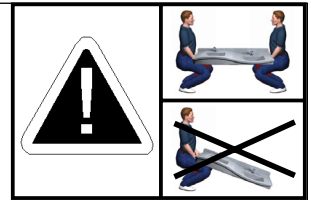

A Install two 3/8" wall anchors (supplied by installer) which will be used to mount the bowl to wall (see rough-ins on page 4).

B Carefully remove the sprayhead cover.

C Carefully lift the bowl onto the pedestal frame using appropriate lifting procedures. Ensure bowl remains 3-4" from the wall.

D Install the two wall anchor brackets to the back of the bowl using the 3/8"- 16 x 1-1/2" hex-head bolts, 13/32" I.D. plain washers, anchor plates, lockwashers, and hex nuts provided.

E Uncoil the infrared sensor leads and plastic tubing from the rear of the backsplash.

F Slide the bowl back to the wall and secure the bowl's wall brackets to the wall anchors with two 3/8" bolts and washers (supplied by installer).

G Fasten the bowl to the upper bracket on the pedestal frame with the two 1/4"- 20 x 1/2" round-head screws and 5/16" I.D. washers supplied.

H Install the drain spud in the bowl using plumber's putty.

I From beneath bowl, thread the spud washer and spud locknut onto the drain spud and tighten the locknut against the bowl.

J Install strainer in the bowl drain using the two #10-24 x 1/2" flat socket head screws supplied.

K Connect the drain trap (supplied by installer) to the drain spud and drain line.

Back View of Washfountain Bowl

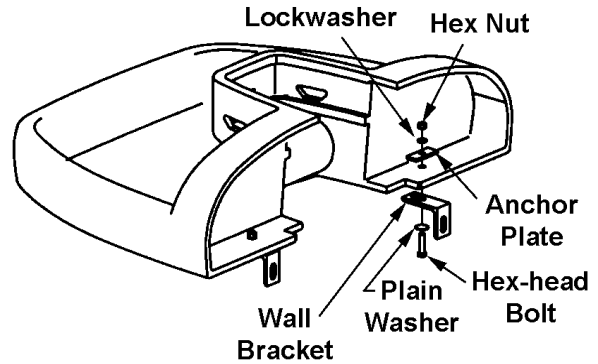

Drain Assembly

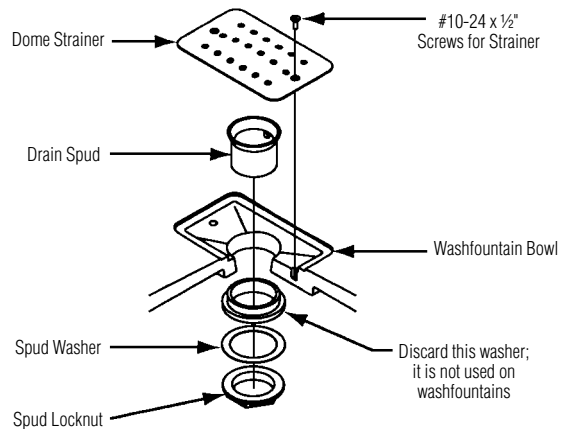

5 Electrical and Supply Connections

A Snap the sensor circuit plug from the bowl into the solenoid circuit plug located on the valve bracket.

B Snap the transformer circuit plug into the female transformer circuit plug located on the valve bracket.

C Insert four different colored sprayhead supply tubes into four solenoid tube connectors by loosening tube connector cap and firmly pushing tubing into tube connector until the tubes are fully seated. Then retighten connector cap.

 The Adaptive Infrared control must be connected with a 24 VAC Class II transformer. Connections to 110 VAC can cause personal injury and will result in damage to the electronics.

 Connections of leads other than shown may cause permanent damage to the sensor.

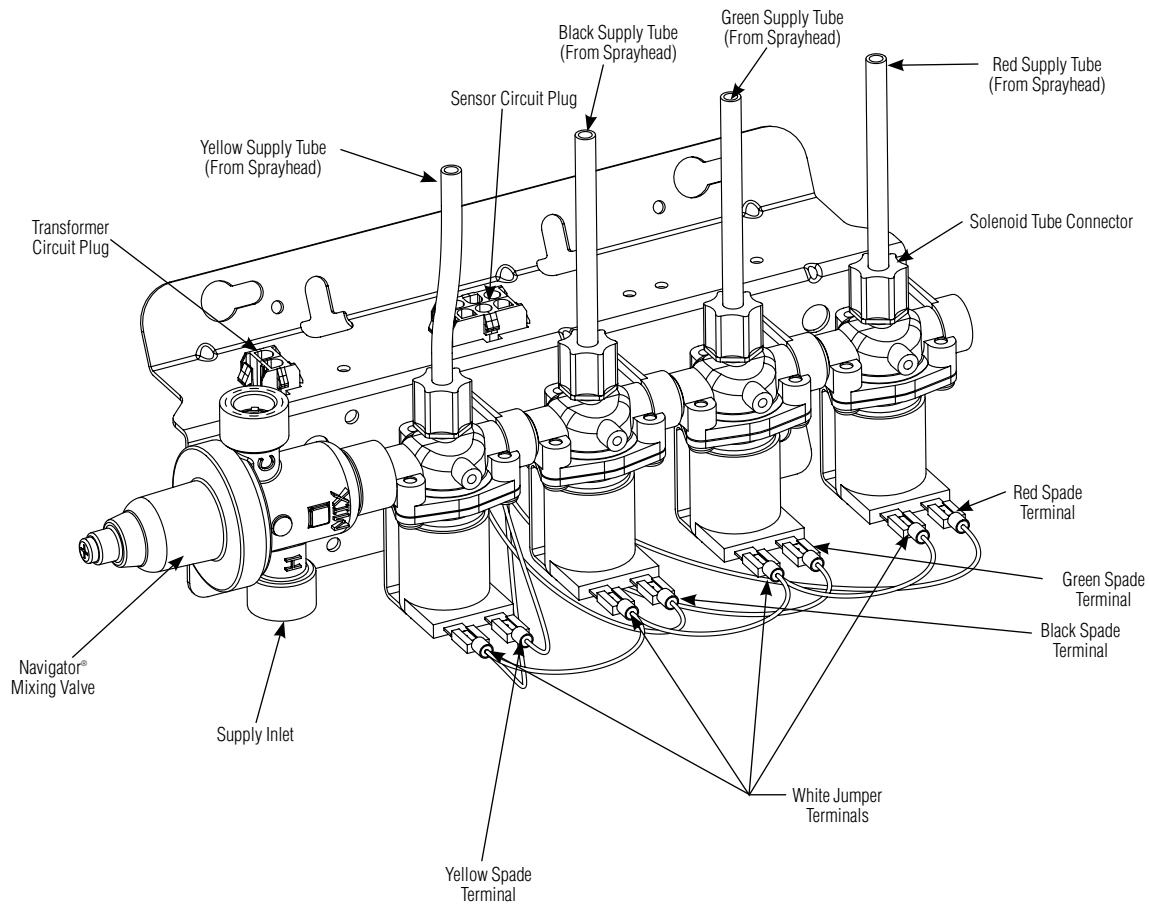

6 Check Operation

A Check to make sure both stops are fully open (see page 5).

B Turn on the main water supply to the Quadra-Fount and check for leaks.

C Turn on the electrical power and pass your hand in front of each sensor until air is purged from the lines.

D Loosen Cap Screw about 1/4" (4-6 turns) and lift up cover (do not remove).

E Using cover, turn cartridge gently until desired water temperature is reached. Do not turn past stops as this may damage unit. Push cover down and tighten screw.



This valve is NOT factory preset. Upon installation, the temperature of this valve must be checked and adjusted to ensure delivery of a safe water temperature. Water in excess of 110°F (43°C) may cause scalding.

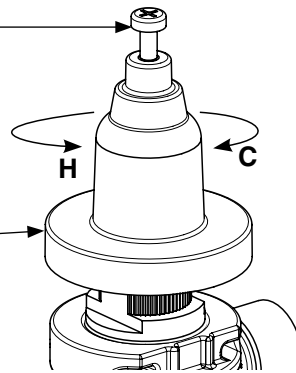

7 Install Top Cover and Front Panel

A Carefully place the top cover with threaded rods on top of washfountain sprayhead.

B Inside the pedestal assembly of the washfountain (use front access), slide the anchor plate onto the threaded rods and secure anchor plate against bowl using the wing nuts provided.

C Install a #10-32 x 3/8" screw (supplied) through the welded nut on the bottom flange of the access panel. Do not tighten.

D Position the access panel by sliding the screw into the bracket slot on the pedestal frame.

E Secure the access panel to the top of the pedestal frame using the self retaining screw.

F Tighten the screw to secure the bottom of the access panel in place.

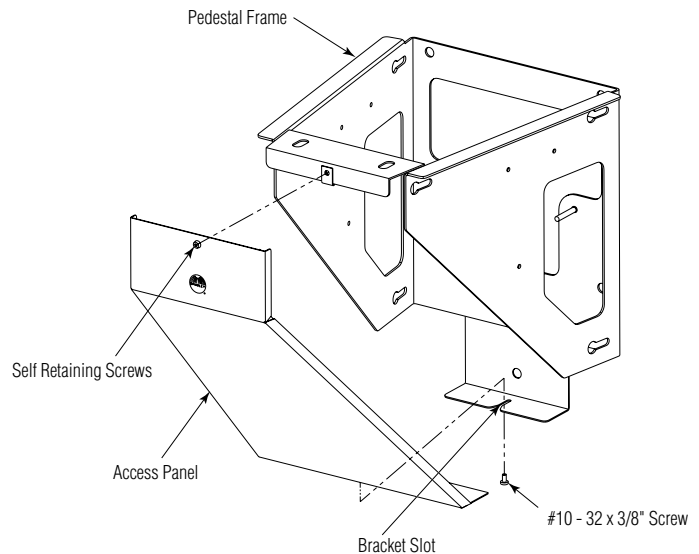
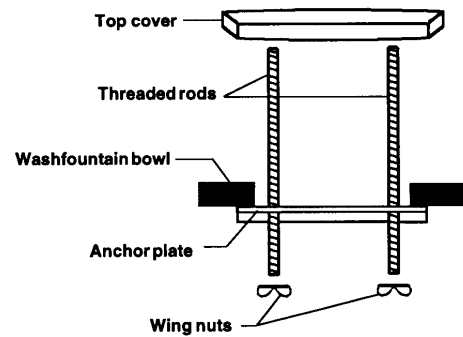

Cleaning and maintenance instructions for Terreon

Material Description: Terreon is an NAHB Certified densified solid surface material composed of polyester resin and is resistant to chemicals, stains, burns and impact. Surface damage can be easily repaired with everyday cleansers or fine grit abrasives.

Routine Cleaning: Clean daily or as often as conditions require using a standard commercial or household cleaner such as Formula 409® or Windex®.

Stubborn Stains: Remove tough stains with Ajax®, Comet®, or Soft-Scrub® and a green Scotch-Brite® pad or lightly sand in a circular motion with 240 grit wet/dry sandpaper. The finish can be renewed with a maroon Scotch-Brite pad.

Special Situations for Material

Scratches: Remove scratches with a green Scotch-Brite® pad. The finish can then be renewed with a maroon Scotch-Brite® pad.

Hard Water Deposits: Remove hard water deposits with a mild solution of vinegar and water. Always rinse the unit thoroughly after cleaning.

Restoring the surface: Use Hope's® Solid Surface cleaner and polish to refresh and protect the Terreon Solid Surface material. Bradley recommends additional care and maintenance for the darker colored Terreon. For complete instructions on this additional maintenance see Bradley document #1505.



Do not use strong acid or alkaline chemicals and cleansers to clean Terreon. If these chemicals come in contact with the terreon surface, wipe them off immediately and rinse with soapy water.

Avoid contact with harsh chemicals such as paint remover, bleach, acetone, etc. Avoid contact with hot pans and objects.

Repair Kits: Terreon repair kits are available. Contact your Bradley representative or distributor for part numbers and pricing.



Repair kits are made to order and have a shelf life of 30 days.

Brand Names: Use of brand names is intended only to indicate a type of cleaner. This does not constitute an endorsement, nor does the omission of any brand name cleaner imply its inadequacy. Many products named are regional in distribution, and can be found in local supermarkets, department and hardware stores, or through your cleaning service. It is emphasized that all products should be used in strict accordance with package instructions.



When cleaning units equipped with infrared (electronic eye) activation, it is helpful to turn off the power to the unit or cover the windows to prevent accidental activation. After the window is covered, the water will run for approximately 30 seconds and then shut off.

Cleaning and maintenance instructions for stainless steel

Material Description: Stainless steel is extremely durable, and maintenance is simple and inexpensive. Proper care, particularly under corrosive conditions, is essential. Always start with the simplest solution and work your way toward the more complicated.

Routine cleaning: Daily or as often as needed use a solution of warm water and soap, detergent, or ammonia. Apply the cleaning solution per the manufacturer's instructions and always use a soft cloth or sponge to avoid damaging the finish.

Stubborn Stains: To remove stains from stainless steel use a stainless steel cleaner and polish such as Ball® stainless steel cleaner or a soft abrasive. Always follow the manufacturer's instructions and apply in the same direction as the polish lines.



Never use ordinary steel wool or steel brushes on stainless steel. Always use stainless steel wool or stainless steel brushes.

Special Situations for Material

Fingerprints and Smears: To remove fingerprints or smears use a high quality stainless steel cleaner and polish in accordance with the manufacturer's instructions. Many of these products leave a protective coating that helps prevent future smears and fingerprints.

Grease and Oil : To remove grease and oil use a quality commercial detergent or caustic cleaner. Apply in accordance to the manufacturer's instructions and in the direction of the polish lines.

Precautions: Avoid prolonged contact with chlorides (bleaches, salts), bromides (sanitizing agents), thiocyanates (pesticides, photography chemicals, and some foods), and iodides on stainless steel equipment, especially if acid conditions exist.



Do not permit salty solutions to evaporate and dry on stainless steel.

The appearance of rust streaks on stainless steel leads to the belief that the stainless steel is rusting. Look for the actual source of the rust in some iron or steel particles which may be touching, but not actually a part of the stainless steel structure.



Strongly acidic or caustic cleaners may attack the steel, causing a reddish film to appear. The use of these cleaners should be avoided.

Brand Names: Use of brand names is intended only to indicate a type of cleaner. This does not constitute an endorsement, nor does the omission of any brand name cleaner imply its inadequacy. Many products named are regional in distribution, and can be found in local supermarkets, department and hardware stores, or through your cleaning service. It is emphasized that all products should be used in strict accordance with package instructions.

Troubleshooting – Solenoid Valve: Part nos. S07-068S (closed body) & S07-068AS (thru body)

Item	Qty.	Part No.	Description
1	1	118-307	Valve Body, ¼" Closed
1	1	118-307A	Valve Body, ¼" Thru
2	1	269-983	Diaphragm
3	1	269-577	Armature
4	1	269-578	Spring
5	1	269-1729	Armature Housing
6	1	269-1730	Clamp, Armature Housing
7	1	269-579	Coil, Solenoid Valve
8	3	160-447	Screw, #8 x 5/8
9	1	125-165	O-Ring, #2-013
10	1	125-160	Flow Restrictor, .5 GPM

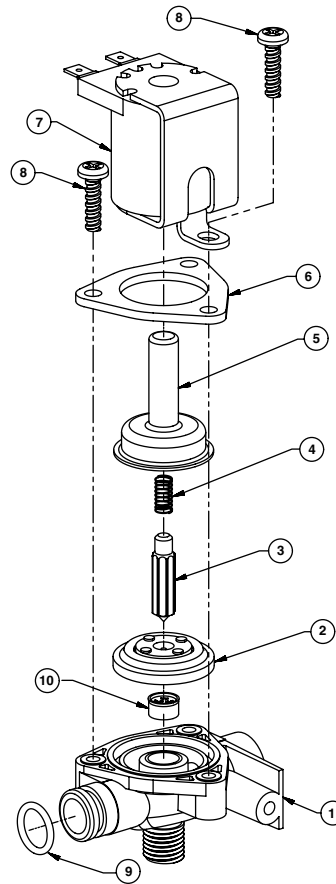

Turn off water supplies to unit before troubleshooting.

Problem	Cause	Solution
An individual operating station fails to shut off and drips.	Debris is trapped between the diaphragm and the valve seat.	<p>Remove debris between diaphragm and the valve seat.</p> <ol style="list-style-type: none"> 1. Remove the three #8 Phillips-head screws that hold the solenoid valve assembly together. Be careful not to lose the armature or spring. 2. Remove the diaphragm. Remove any particles that have been trapped between the diaphragm and the valve seat. Rinse off the diaphragm and inspect for damage. Make sure the center orifice and both small side orifices are open. 3. Reassemble in reverse order (do not overtighten the Phillips-head screws or the plastic valve body may crack). Tighten until the armature plate makes contact with the plastic body. 4. Reconnect the wiring.
An individual operating station fails to turn on.	A failed coil for the valve or loose electrical connection to the terminal.	<p>Test the station to determine the cause.</p> <ol style="list-style-type: none"> 1. Disconnect the wires from the coil of an adjacent valve. Disconnect the wires from the problem valve and reconnect to the adjacent valve. 2. Turn on electrical and water supplies to the unit. Pass your hand in front of the sensor of the problem station, and the adjacent station should turn on. <p>If the adjacent station turns on and cycles normally, replace the coil on the problem valve.</p> <p>If the adjacent valve fails to turn on, inspect the wires from the sensor cable and do the following:</p> <ul style="list-style-type: none"> • make sure there are no breaks and that the fully insulated disconnect terminals are firmly crimped in place; • turn off the electrical and water supplies; • reconnect to the adjacent valve and turn on the water supplies to the unit; • pass your hand in front of the sensor. If the station still fails to turn on, replace the sensor.

Thermostatic Mixing Valve Troubleshooting



Before attempting to troubleshoot the valve or disassemble the components, check for the following conditions:

- If stop valves are used, make sure that they are fully open.
- Make sure that the hot and cold inlet pipes are connected properly, and that there are no cross-connections or leaking stop valves.
- Check the hot water heater output to make sure that it is at least 10° F above the set temperature.



Be sure to close the appropriate shut-off valves prior to disassembly of the valve and reopen the valves after inspection and repair is complete.

Problem	Cause	Solution
External leaks.	Damaged cartridge or O-rings.	Replace cartridge with part number 269-1927
Improper water temperature or temperature fluctuation.	Hot water supply is not 10° above desired set point.	Increase hot water supply temperature
	Valve temperature is not properly set.	Adjust the temperature as shown on page 8 step 6.
Limited water flow.	Dirt and debris have built up in the valve or strainer.	1. Check to make sure both hot and cold supplies are connected to the Navigator mixing valve and that they have water flow. 2. Remove cover and U-clip. Remove the cartridge and clean the strainer. It is not required to grease cartridge, however if desired, use silicone grease only. Do not use grease on check valves.

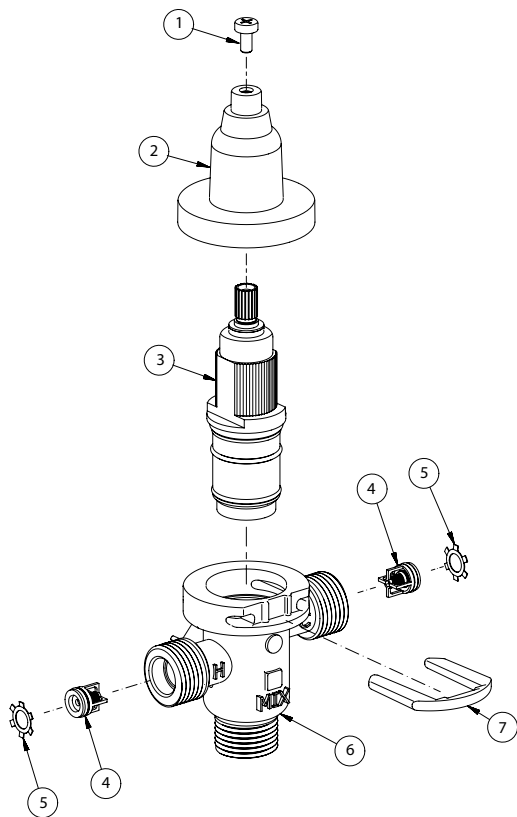

Parts List

Item	Part No.	Description	Quantity
			S59-4000
1	160-463	Cap Screw	1
2	107-582	Cover	1
3	269-1927	Thermostatic Cartridge	1
4	198-014	Check Valve*	2
5	132-051	Retaining Ring*	2
6	118-319	Valve Body	1
7	146-079	U-Clip	1

* Included with Prepack S65-326

Tempered Line Adapter Option Part no. S39-804

(replaces S59-4000 if tempered line is used)

